

Threaded Headset

Instruction Manual

HS005

Please read all instructions before installing your new threaded headset.

Warning

Failure to install headsets properly may result in damage to your bicycle, serious injury, and/or death.

Note: Installation requires specialized equipment to press fittings onto the steerer tube and into the head tube.

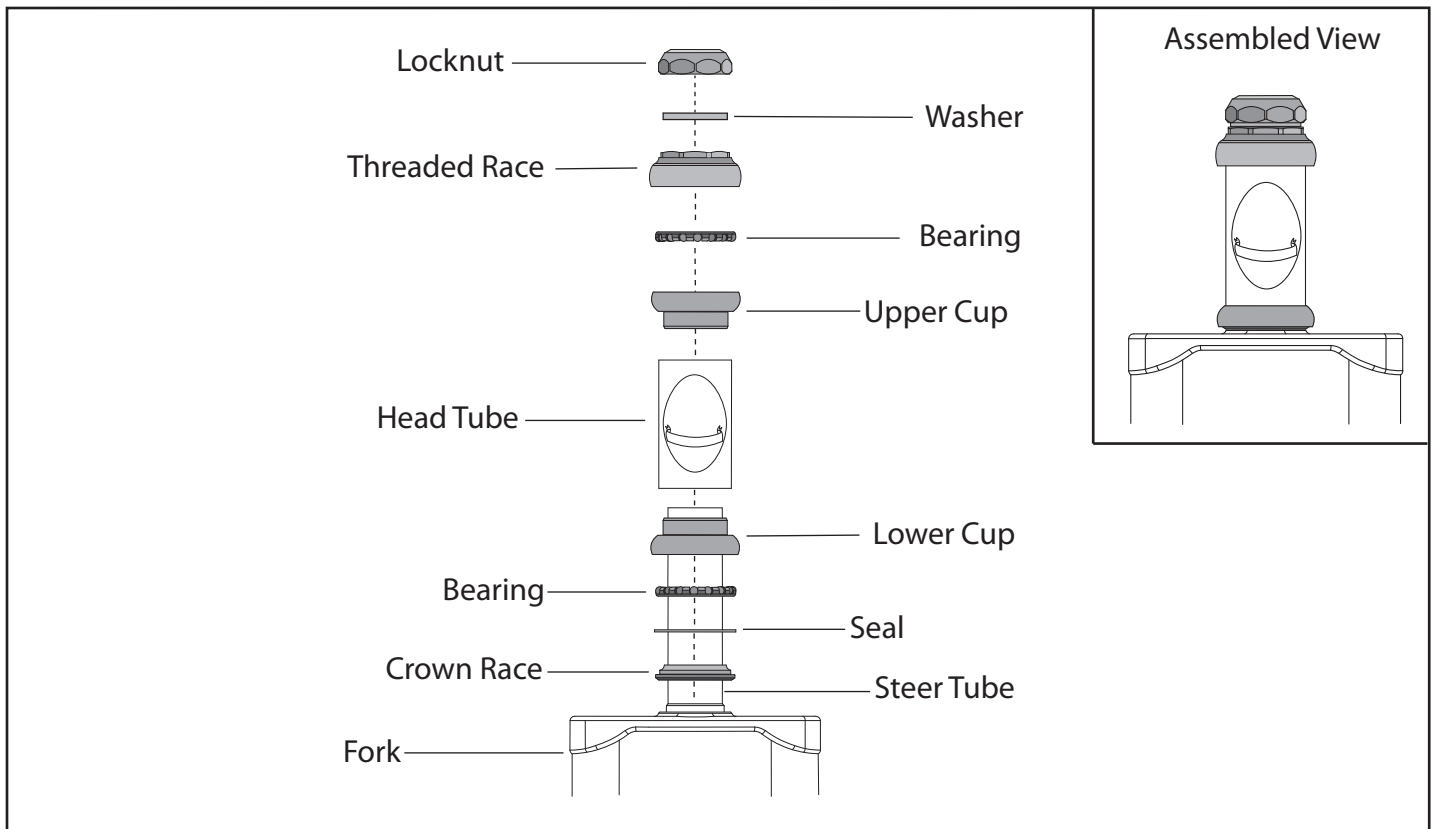

Installation

1. Install crown race to fork using an appropriate press. Fitment should be flush and evenly seated.
2. Place seal and bearing over the steerer tube taking note of the bearings orientation. Set aside.
3. Install upper and lower cups to the head tube using a headset press.
4. Insert fitted steerer tube through the head tube. Place the bearing onto the steerer tube as illustrated.
5. Install threaded race over the steerer tube and tighten until contact with bearing. The fit should be as loose as possible without any play in the system. Do not over tighten.
6. Install washer and locknut, tighten locknut to approximately 24Nm.
7. Install stem and handlebar. Check for smooth operation without play. Repeat steps 5 and 6 if play exists.
8. If play is detected after adjusting the threaded race, check if all bearing, cups, and races are flush with their respective surfaces. If steering is difficult, loosen the thread race a quarter-turn and recheck.

SUNLITE