

# Full Fender

## Instruction Manual

FF009

*Please read all instructions before installing and using your new fenders.*

Additional hardware may be necessary for Installation - Does not include eyelet (M5) or brake mount (M6) bolts.

### Warning

Failure to install fenders properly may result in serious injury/death and or damage to your bicycle.

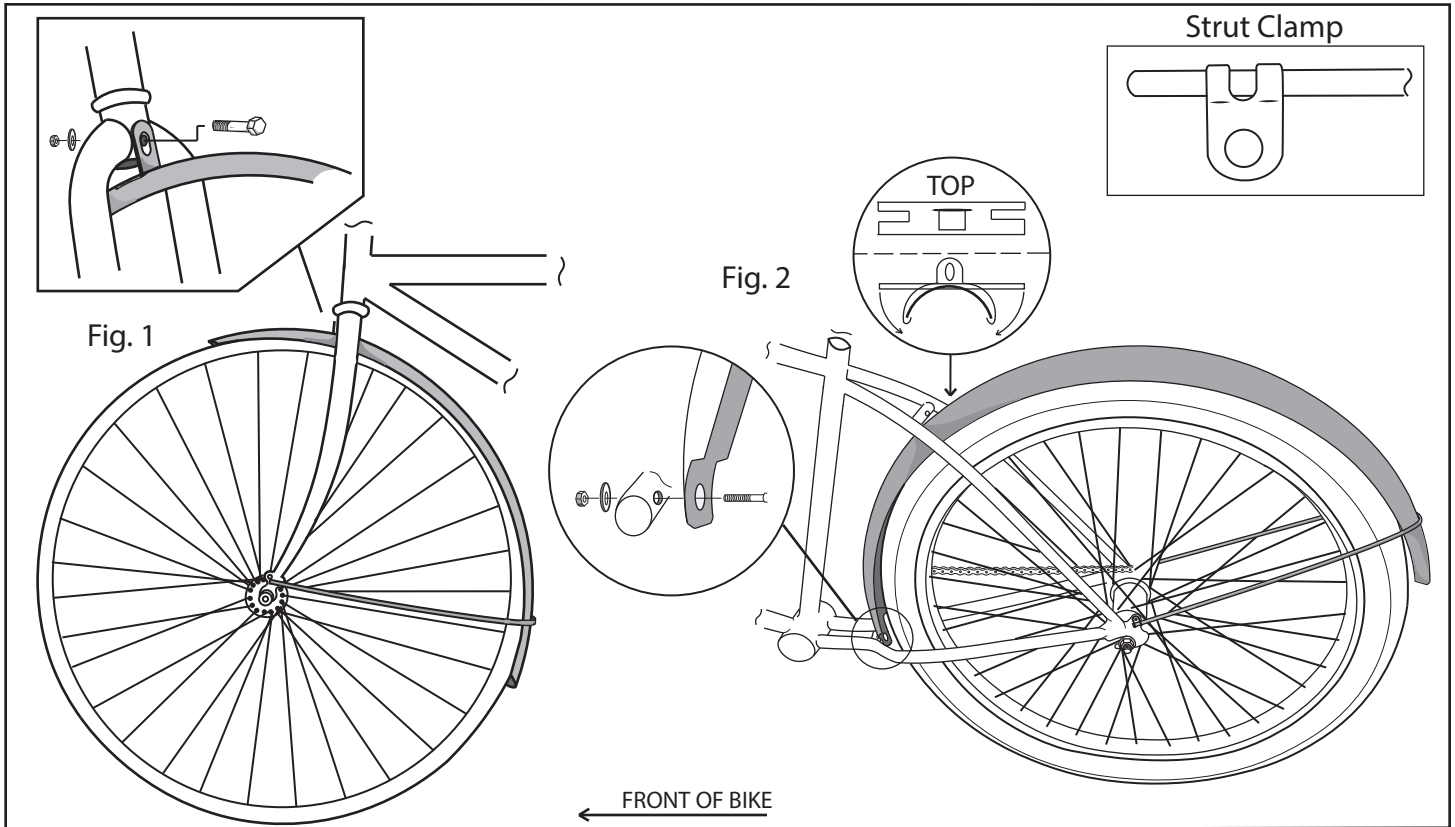

## Installation

### Front - (Figure 1)

1. Pass the tabless end of the fender through the fork until the tab is lined up with the fork's brake hole.
2. Secure fender to brake hole mount in fork using an M6 bolt or brake caliper mount. (Not included)
3. Adjust strut clamp to proper position on the strut and secure to fork using an eyelet bolt. (not included)
4. Double check clearance and adjust as needed to ensure there is no contact with the tire.

### Rear - (Figure 2)

1. Attach strut to fender using supplied nut and bolt.
2. Position fender how it will be mounted, aligning end tab to chainstay bridge hole.
3. Fasten fender tab to bridge - (See Fig 2 inset) (Hardware not included)
4. Align optional bridge clip to seat stay brake mount and fold side tabs securely around the fender.
5. Install brake bolt to bridge clip and secure.
6. Adjust strut clamp to proper position on the strut and secure to frame using an eyelet bolt. (not included)
7. Double check clearance and adjust as needed to ensure there is no contact with the tire.

**SUNLITE**