

# Square Taper Crankset

## Instruction Manual

CS-001

*Please read all instructions before installing and using your crankset.*

### Warning

Failure to install cranksets properly may result in serious injury/death and or damage to your bicycle.

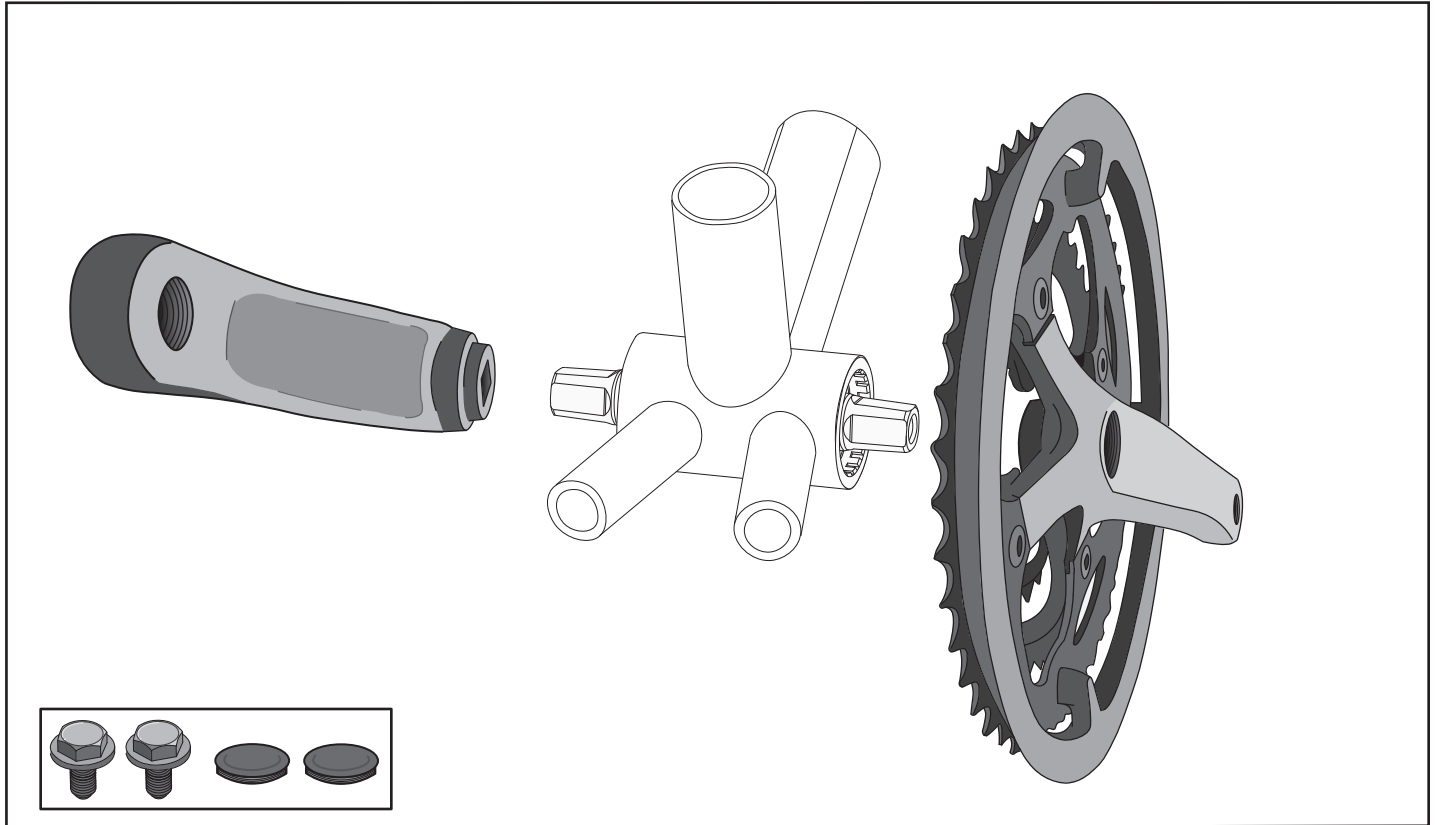

## Installation

1. Clean square tapers of BB spindle with rubbing alcohol - do not grease.
2. Push drive side crank onto spindle.
3. Grease the crank bolt and thread it into the spindle until tightly seated.
4. Repeat same process for non drive side ensuring not to cross thread the bolts.
5. Torque both sides to 38-42Nm using a torque wrench.
6. Rotate crank checking clearance as well and smooth motion throughout the rotation.
7. Replace dust covers.

**SUNLITE**